

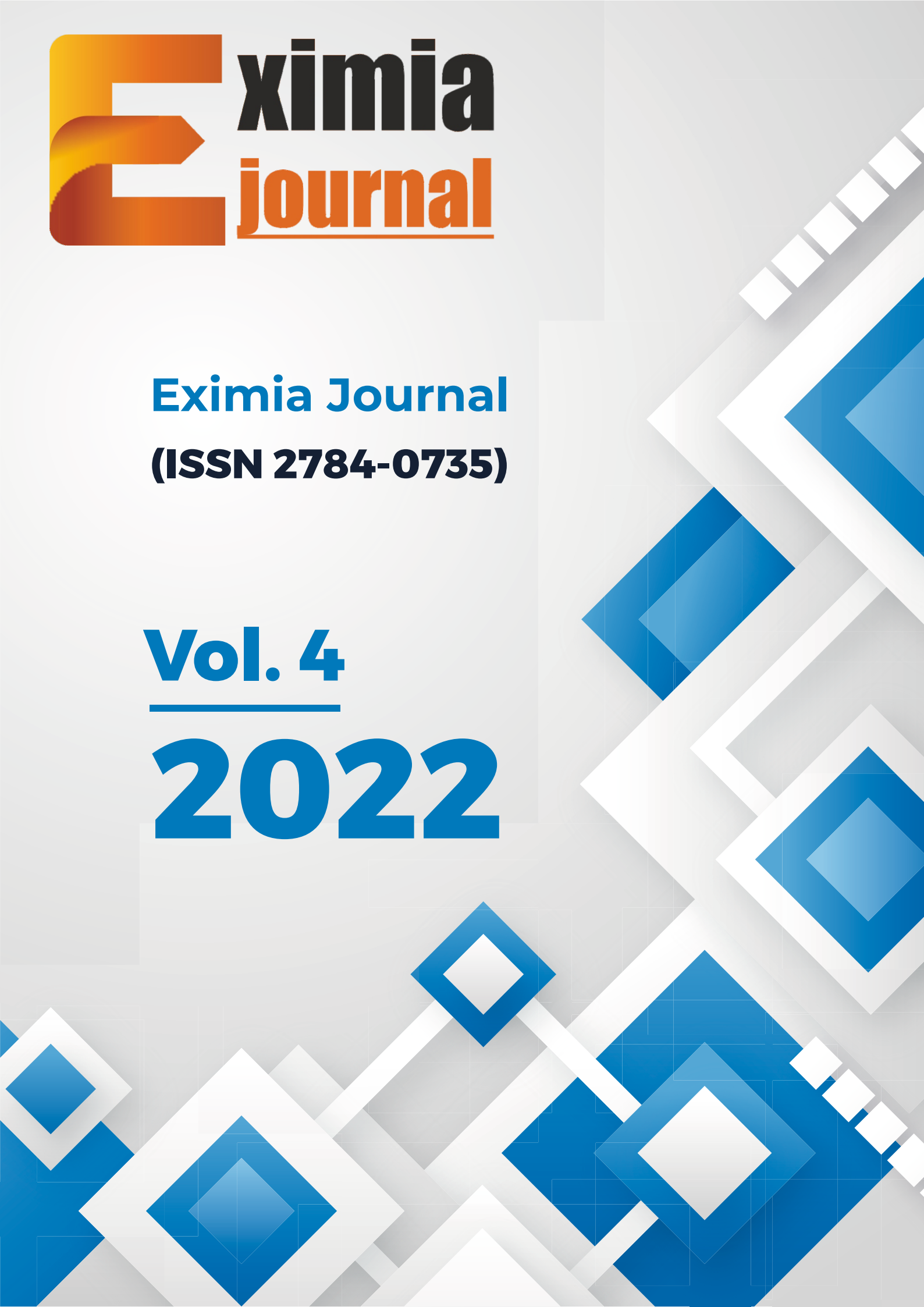

Eximia Journal
(ISSN 2784-0735)

Vol. 4

2022



Development of a Long-Range WAN Weather and Soil Monitoring System for Rural Farmers

Uchechi C. Njoku¹, Cosmas K. Agubor², Longinus S. Ezema³

^{1,2,3}Department of Electrical and Electronic Engineering, Federal University of Technology, Owerri, Imo State, Nigeria

newmanuchechi@gmail.com

Abstract. Increasing security concerns in areas where insurgency persist, calls for reduced visitation of the farmers to their farms, consequently affecting produce. This calls for remote monitoring of the environmental weather and soil conditions of the farmland in order to trigger irrigation automatically. Traditional broadband systems used for remote monitoring of soil and environmental weather conditions require high cost and focuses on enabling high data rates per device and are not energy efficient. In this work, Long Range Wireless Area Network (LoRaWAN) has been presented, a new trend in the evolution of the wireless communication technologies to provide energy efficient system that requires no data cost for monitoring. In achieving this, BME280-Temperature, Humidity and Pressure Sensors, ESP32 LoRa transmitter and receiver modules were used. Arduino C++ programming language was used for the ESP32 controller. A wireless access point was established between the transmitter and receiver; and sensor-data was transmitted seamlessly from the transmitter to the receiver, updating every 10seconds. The result at the receiver visualized on the Organic Light Emitting Diodes (OLED) or via mobile phone at no data cost shows the Received Signal Strength Indicator (RSSI), Temperature, Pressure and Humidity values at real time. Automatic DC Sprinkler system triggered when the BME280 sensor threshold values for pressure and temperature were met.

Keywords. BME280 Sensors, DC Sprinkler, ESP32 LoRa, OLED, RSSI

1. Introduction

Farmers in rural areas where network connectivity to farmlands is deficient or require high data cost to connect to internet for update on environmental weather and soil conditions would have to visit the farmland regularly. With increasing security threat to the lives of farmers now, especially in some countries like Nigeria where there are reports of frequent farmer-herders' clashes, it calls for reduced visitation to the farmlands. A Wireless Sensor Network (WSN) solution with low power consumption for remote monitoring of surrounding environmental conditions of the farmland, becomes a necessity [1]. Amongst other things, it will help the farmer to know exactly when to irrigate the farm manually or trigger such remotely in the case of a smart farm with automated irrigation system. In both cases, it will reduce the frequency of visitation to the farmlands due to the afore-mentioned threats.

Long Range Wide Area Network (LoRaWAN) technology represent a new trend in the evolution of the wireless communication technologies. Unlike the traditional broadband, this

system does not focus on enabling high data rates per device. Instead, the key performance metrics defined for this systems are energy efficiency, scalability and coverage. The Bandwidth Vs Range Plot of LoRa in comparison with other existing technologies such as WiFi and Cellular Networks are shown in Figure 1. LoRa provides for long-range communications up to 5 kilometers in urban areas, and up to 15 kilometers or more in rural areas (line of sight). A key characteristic of the LoRa-based solutions is ultra-low power requirements, which allows for the creation of battery-operated devices that can last for up to 10 years. However, the most critical drawbacks are low reliability, substantial delays and potentially poor performance in terms of downlink traffic [3] [4].

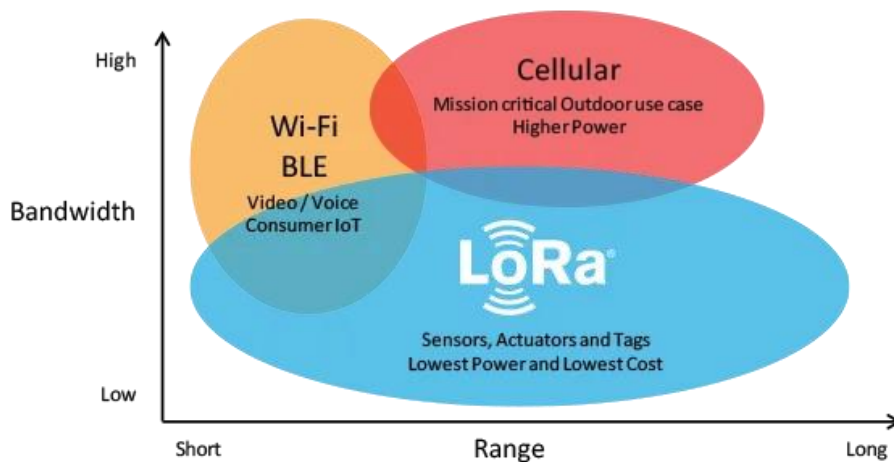

Figure 1: Bandwidth vs. Range of Wireless Technologies [2]

Deployed in a star topology, a network based on the open LoRaWAN protocol is perfect for applications that require long-range communication among a large number of devices that have low power requirements and that collect small amounts of data. LoRa can be effectively utilized for the moderately dense networks of very low traffic devices which do not impose strict latency or reliability requirements. Among the possible example use cases are, non-critical infrastructure or environment monitoring applications [5].

Various sensors which continuously monitor the field are deployed to collect data from the field. The soil moisture sensor measures the moisture content of the soil. The BH1750 sensor reads the weather condition of the field. PT100 Sensor senses the temperature of the field. These sensor-data is the input data to the system [6] [7].

Different approaches in this field of study have been conducted by researchers. In [8], the system used Ethernet communication for data packets transfer from the transmitter to the receiver. Cost of installing underground cable is high. Wireless solution is required. In [9], data can only be transmitted reliably 3 km farther away from gateway and devices. An improvement on the distance is needed. Elsewhere, comparison was made between LoRa and IEEE 802.15.4-Based IoT Deployments [10]. Utilizing LoRa for practical application is required. In [11], the received data was stored in IBM cloud DB service and can only be accessed over the internet. Standalone Wireless Access Point is required to eliminate data subscription cost.

In this work, Long Range Wireless Area Network (LoRaWAN) has been presented, a new trend in the evolution of the wireless communication technologies to provide energy efficient system that requires no data cost for monitoring soil and atmospheric conditions of the farmland over a longer distance. Furthermore, an automatic irrigation system was designed and triggered when

the threshold temperature and pressure were met, eliminating the need to visit the farmland for that purpose.

The novelty of this work is that it presents the feasibility and efficiency of an alternate network architecture for wireless access point as a sensing platform for rural farmers to be able to capture data from relatively distant farm.

2. Materials and Methods

2.1. Materials

Materials used are divided into Hardware and Software. The Hardware Materials include: ESP32 LoRa Transmitter Module, ESP32 LoRa Receiver Module, OLED, 12 V battery, 9 V battery, 12 V DC Sprinkler, ESP32 Controller, BME280 - Temperature, Humidity and Pressure Sensor. The Software Materials include: Arduino C++ Programming Language, Proteus Simulation Software.

2.2. Methods

2.2.1. *Design of Remote Monitoring System.* A wireless access point was established between the transmitter and receiver; and sensor-data was transmitted from the transmitter to the receiver some distance apart.

i) Transmitter System Block Diagram

Figure 2 depicts the transmitter block diagram and the flow of signals begins from the power source to the LoRa module (transmitter). The sensor data are displayed on the OLED in form of packets, transmitted via an antenna coupled to the transmitter.

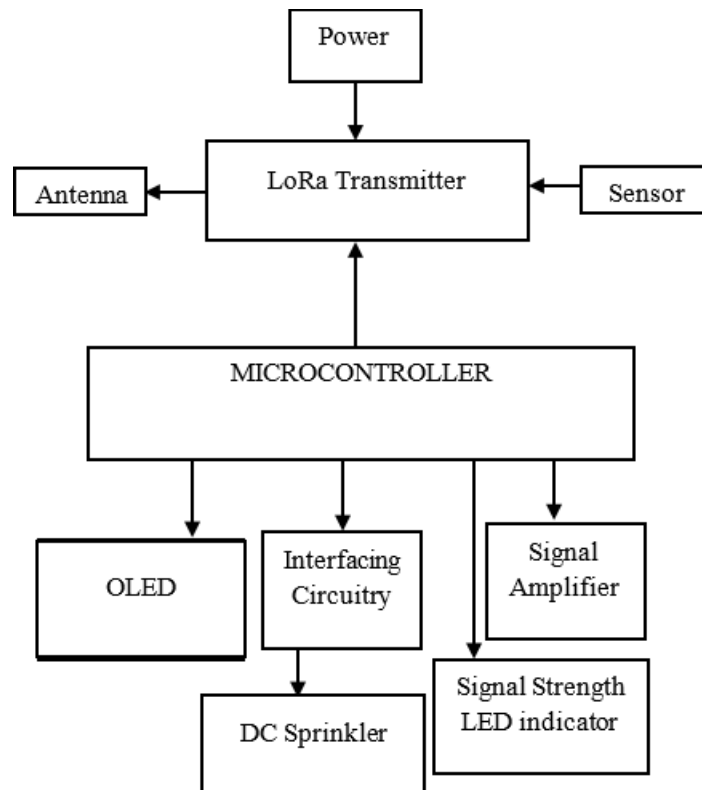

Figure 2: Transmitter Block Diagram

ii) Transmitter System flowchart

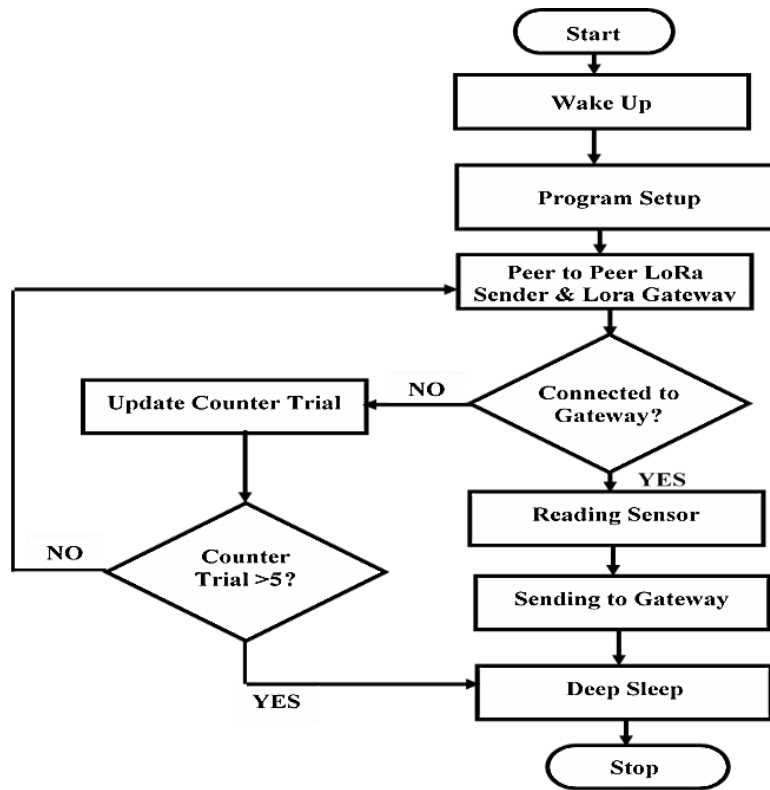

Figure 3: Flowchart of LoRa Transmitter System

Figure 3 shows the flow of signals in the ESP LoRa transmitter module before sending out the packets to the receiver. The transmitter unit goes into sleep mode when there is no nearby receiver of the same frequency. But as soon as the receiver is switched on, the transmitter quickly begins to send packets.

iii) Transmitter Circuit Diagram

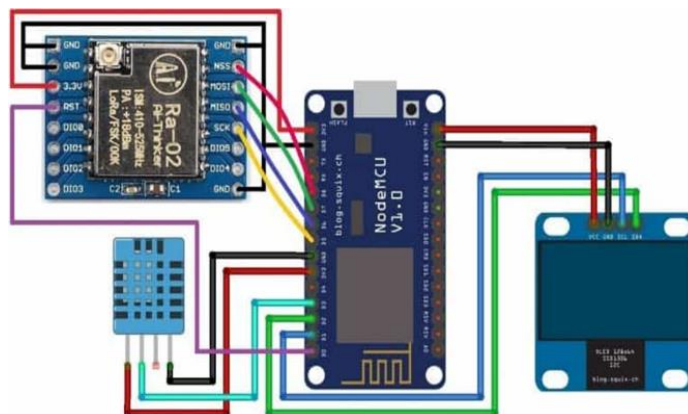

Figure 4: Circuit diagram of ESP LoRa Transmitter network

Figure 4 shows the circuit diagram of LoRa Transmitter network; made up of LoRa module and OLED at the left hand side connected to the Controller and the Sensor module at the right hand

side. The pressure, temperature and humidity sensors were connected to the Transmitter end. The data from the transmitter is sent to the receiver in form of packets with a defined password which restricts other receivers within the same frequency of operation to transmit.

iv) Transmitter / Receiver System Algorithm

The following are the system algorithm:

- i. Initialization of the Controller ports;
- ii. Sensors intimate with the environmental conditions;
- iii. OLED Screen displays;
- iv. Wi-Fi module wakes up from the Sleep mode;
- v. Sensors ready to send data packet through the transmitter to the receiver wirelessly;
- vi. Wi-Fi module transmitter ready to send to the Receiver;
- vii. Wi-Fi module Receiver receive packets (temperature, pressure and humidity) from the transmitter concurrently;
- viii. Controller gets ready to get data from the transmitter and displays on the OLED screen using I2C data packet transmission protocol;
- ix. Receiver Controller finally receives data from the Transmitter Controller and displays on the OLED Screen;
- x. Transmitter module updates its sensor data packet and sends to the receiver and the processes repeat.

v) Receiver Block Diagram

Figure 5 depicts the receiver block diagram and the flow of signals begins from the power source to the LoRa module (receiver). The OLED displays the readings from BME280 - temperature, humidity and pressure sensors in form of packets.

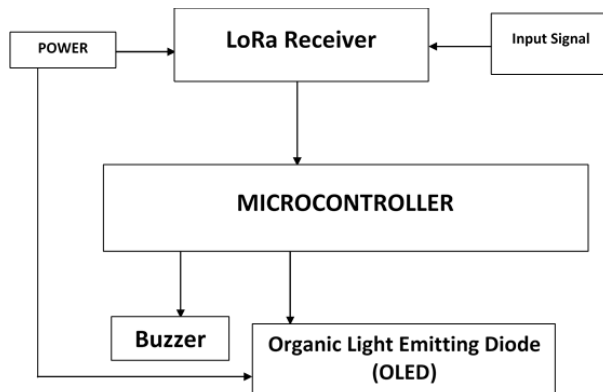

Figure 5: Receiver Block Diagram

vi) Receiver System Flowchart

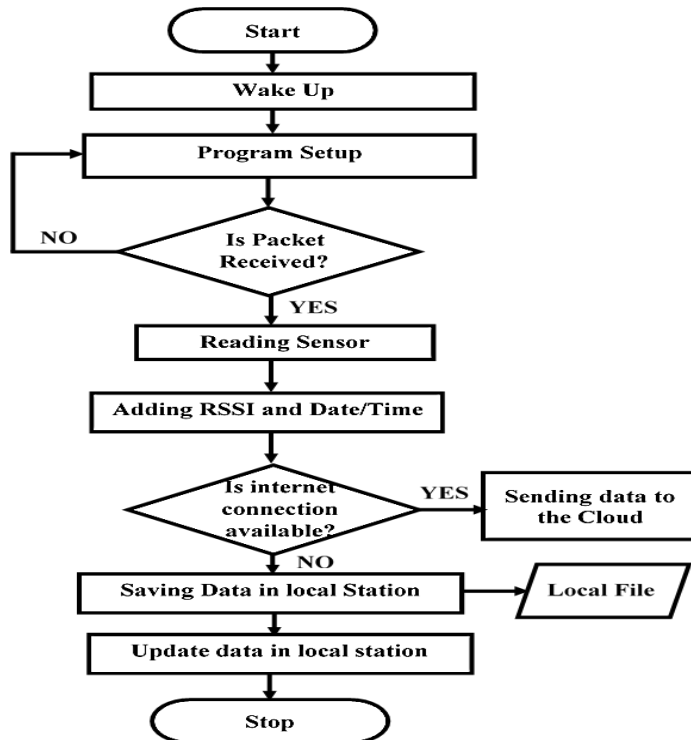

Figure 6: Flowchart of LoRa Receiver System

vii) Receiver Circuit Diagram

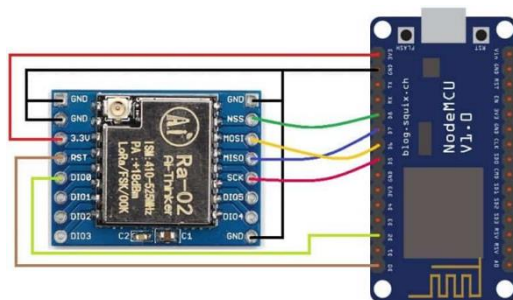

Figure 7: Circuit diagram of ESP LoRa Receiver

Figure 6 shows the flow of signals in the ESP32 LoRa receiver module and there must be a handshake between the transmitter and receiver before packets will be sent or received. Figure 7 shows the circuit diagram of ESP LoRa Receiver network which consists of the ESP LoRa and the Controller modules. When the transmitter sends packets, the Receiver checks for matching of access credentials (frequency band) and if they are the same, packets are then received including the Received Signal Strength Indicator (RSSI).

viii) TTGO LORA32 Specification

The TTGO LoRa32 SX1276 OLED is an ESP32 development board with a built-in LoRa chip and an SSD1306 0.96-inch OLED display. The Specification of TTGO LoRaA32 868/915MHz

SX1276 ESP32 OLED-display BT Wireless WIFI LoRa development board Adapter Board are as listed:

- i. External antenna;
- ii. Lithium battery friendly;
- iii. Input/output port touch screen touch signal input;
- iv. User Datagram Protocol (UDP) sustained throughput of 135 Mbps;
- v. Model: LoRa32 V2.1;
- vi. IC Type: Voltage regulator IC;
- vii. Power: 1 W;
- viii. Frequency range: 915 MHz, 868 MHz, 433 MHz.

2.2.2. *Packets Visualization at the Receiver's end.* When the transmitter sends packets, the Receiver checks for matching of access credentials (frequency band) and if they are the same, packets are then received including the RSSI. ESP32 LoRa receiver module comes with an OLED which displays the readings from BME 280 temperature, humidity and pressure sensor in form of packets. An alternative scheme is to use a laptop or mobile phone as an added feature for data visualization at the receiver's end. The network credentials of the mobile device or router generating hotspot used for visualization is programmed to the receiver in order to visualize the packets from the transmitter via the receiver. The network credentials of the mobile device or router generating hotspot used for visualization is programmed to the receiver in order to visualize the packets from the transmitter via the receiver. The receiver displays its internet protocol (IP) address on the PC serial monitor during the programming stage and it is usually noted for future use. The IP address is entered on any browser (e.g. Firefox, Chrome, Internet Explorer etc.). This opens the webpage for the farmer to visualize the current readings of the three parameters at no data cost.

2.2.3. *Design of DC Power Supply.* The LoRaWAN system deployed for monitoring is a low power consumption system both at the transmitter end and the receiver end.

i) DC Power Supply Stages

Four stages were adopted in building the DC Power Supply for the System.

- i. Transformation
- ii. Rectification
- iii. Filtration
- iv. Regulation

The detailed circuit diagram of power unit is shown in figure 8. Transformation stage is where the high AC voltage is stepped down using a step-down transformer; after the step-down, the voltage output is still AC. Rectification is simply the conversion of AC to DC with the aid of Rectifiers (diodes). Here the bridge rectifier type was deployed because ripples are less in it compared to other types. Filtration is the smoothening/removal of ripples (wasted power or mixture of small amount of AC with DC).

Figure 8: Detailed circuit diagram of power unit

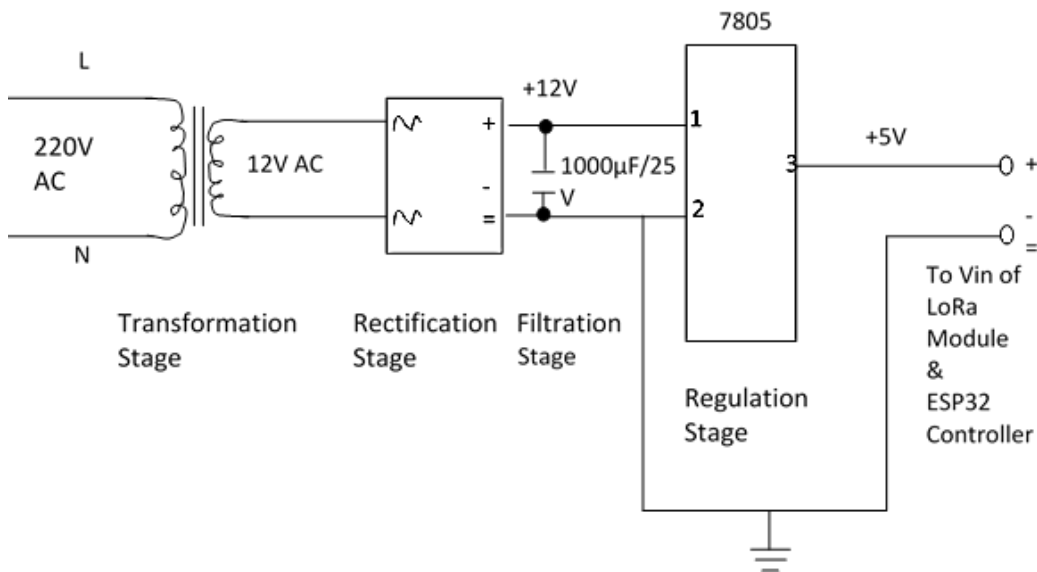

The components values were chosen based on “Equation (1)” to achieve a low ripple factor.

$$\text{Ripple Factor } (\gamma) = \frac{1}{4\sqrt{3}fCR} \quad (1)$$

Frequency, $F = 50 \text{ Hz}$

Capacitor for filtration, $C = 1000 \text{ uF} / 25 \text{ V}$

Load resistance, $R = 1000 \text{ } \Omega$

$$\gamma = \frac{1}{4\sqrt{3} * 50 * 1000 * 10^{-6} * 1000} = 0.02$$

Regulation is the last stage of the Power supply. It’s optional depending on the amount of voltage the load is expecting from the rectifier. There are recommended voltage regulators such as Zener diode, 7805, 7806, 7809, 7812, 7815 and others.

- ii) Power Supply component specifications
 - i. Input AC voltage = 220 V
 - ii. Step down Transformer Primary AC voltage = 220 V (Input AC voltage)
 - iii. Step down transformer Secondary AC voltage = 12 V
 - iv. Rectifier Diode DC Current Capacity = 2 A
 - v. Filtering Capacitor voltage = 1000 µF / 25 V
 - vi. Output DC voltage of Rectifier= 5 V (for the LoRa Receiver module and circuit)
 - vii. Output DC voltage of Rectifier = 12 V (for the Relay interface circuit).

2.2.4. *Design of Automatic Sprinkler System.* Figure 10 shows the circuit diagram of an automatic DC sprinkler which triggers when the BME280 sensor threshold values

are met. The DC sprinkler automatically triggers when the BME280 sensor threshold values are met. The unit consists of a DC water pump which serves as the sprinkler. It is triggered through a 12V DC relay which must receive biasing potential from the BC547 NPN transistor. ESP32 Controller senses the changes at the SCK and SDA pins of BME280 and carries out the predefined tasks at its digital pin 8 (D8). When the humidity was less than 50 % and temperature was less than 26 °C respectively, the controller quickly triggered the sprinkler for 60 seconds and went to sleep mode for an hour before waking up to recheck the nature of the two parameters of interest (Humidity and temperature).

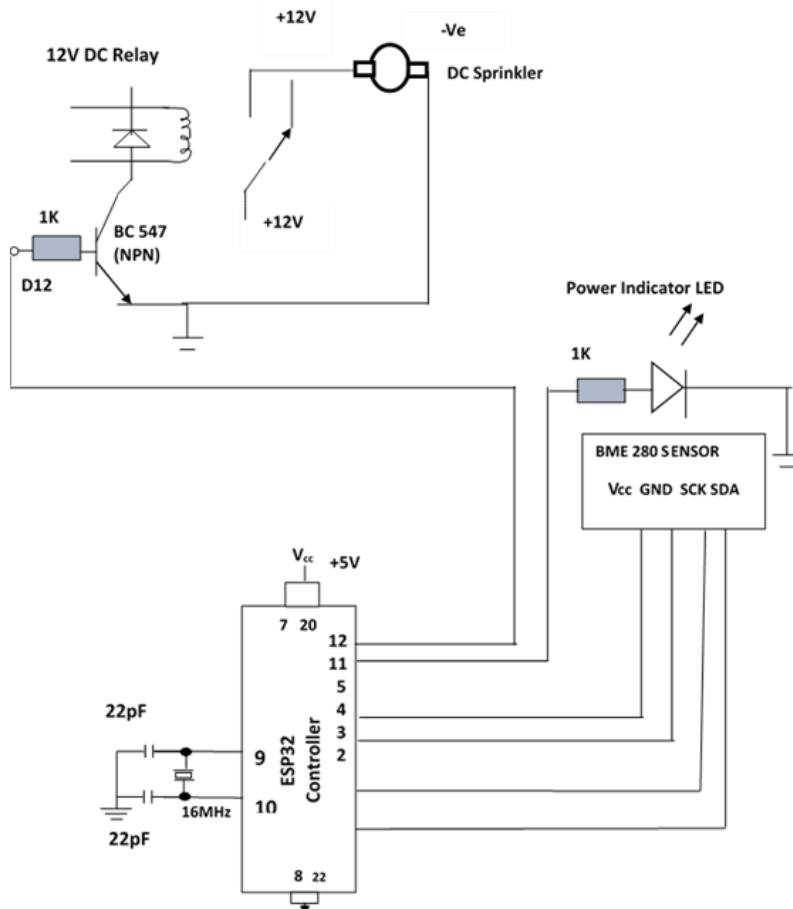

Figure 9: Detailed Circuit Diagram of an Automatic Sprinkler System

2.3 Design Implementation

The system is made up of different sub-systems which were harmonized to form the whole. The system has three major sub-units viz transmitter, receiver and the automation unit. In terms of apparatus, two nodes (receiver and transmitter) were constructed and attached to 2x2 and 4x4 PVC boxes respectively. One node (receiver) was attached with the base of its antenna 10 cm above its ground level, and another (transmitter) was attached with the same base of the antenna. These nodes were programmed with firmware; using Arduino C++ Programming language, which transmitted a packet of fixed length upon being reset, with the data rate used to transmit set by reading a GPIO pin. An ESP32 LoRa module was attached to the BME280 sensor with the control of the relevant general purpose input and output (GPIO) lines on each node.

3. Results and Discussions

3.1 Field Trials

The transmitter was able to send packets as far as 245 m away from the receiver and the readings were taken. A hot soldering iron was placed very close to the BME280 sensor to provide a condition of temperature change of the environment. The sensor was observed to be changing its values accordingly. Then, at the receiver end, it was observed that as the sensor values were changing at the transmitter end, it was also changing at the receiver's end. The observation was made possible by placing a phone call between the person holding the transmitter at a far distance (about 245 m away) and the other person holding the receiver. The average changes in the received signal strength indicator (RSSI) were recorded and tabulated. The automation feature of the system was also tested and when the temperature was equal or less than 26 °C, the system triggered the DC sprinkler and the farm was fully irrigated. Each test was successfully carried out and the anticipated results were obtained accordingly. A dry cell battery (9 v 1 A) of low current capacity was able to power the entire circuit attesting to the system low power consumption nature.

3.2 Receiver Response to the Changes in Sensor Parameters

i) Receiver Signal Strength Indicator (RSSI)

The receiver was able to receive packets from the transmitter seamlessly and as any parameter changed in values, it quickly updated accordingly. Figure 12 shows the results.

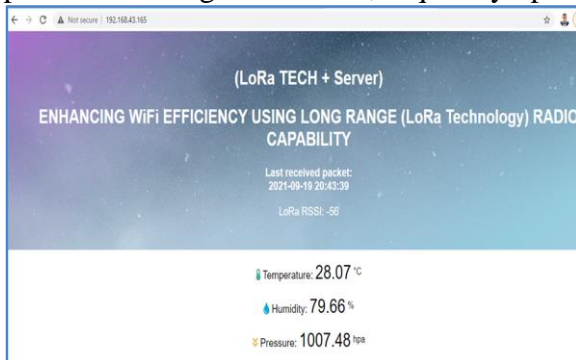

Figure 10 Receiver getting packets from transmitter

Esp32 LoRa technology gives the strength of signal flow between the transmitter and receiver which is called RSSI. The RSSI values of this system were very stable even when the distance kept changing during the system test in an open space. The changes encountered in the values of transceiver's RSSI during the test are summarized in Table 1. The average output power in mW was calculated using "equation (2)".

$$\text{Output power (Pout)} = 10^{\frac{\text{dBm}}{10}} \quad (2)$$

Where the received signal strength indicator is measured in dBm.

Table 1 Communication Range and RSSI values at 1<distance<=245 distance

Distance (m)	Largest RSSI Value (dBm)	Smallest RSSI Value (dBm)	Average (Round off)	Average Output Power (mW)
--------------	--------------------------	---------------------------	---------------------	---------------------------

			RSSI Value (dBm)	
1	-54	-53	-53.5	0.0000029
50	-54	-53	-53.5	0.0000029
100	-55	-53	-54.0	0.0000040
150	-54	-54	-54.0	0.0000040
200	-54	-51	-52.5	0.0000056
245	-51	51	-51.0	0.0000079

The results show that there was minimum power and maximum power at RSSI of -53.5 dBm and -50.5 dBm respectively.

ii) Output (Received) Power Measurement

In wireless sensor network, a cell data device is radio device and the signal strength and signal quality both are measured in dBm (i.e. decibels relative to one milliwatt, is connected to the cellular tower. RSSI is a negative dBm value, values closer to 0 dBm are strong signals.

After calculating the average output power, it was observed that the average output power was greater at -50.5 dBm showing that the closer the transmitter to the receiver, the more the output power vice versa. The maximum output power was 0.0000089 mW whereas the minimum output power was 0.0000029 mW.

Figures 13, 14 and 15 show detailed graphical representations of the corresponding changes in the RSSI at different locations and at constant Time Duration (10 seconds) Careful observations of Figures 13, 14, and 15 show that the signal strength did not fluctuate much; minimum and maximum Average RSSI's of -55 dB and -50.5 dB corresponding to received powers of 0.0000032 mW and 0.0000089 mW respectively for the range of plots.

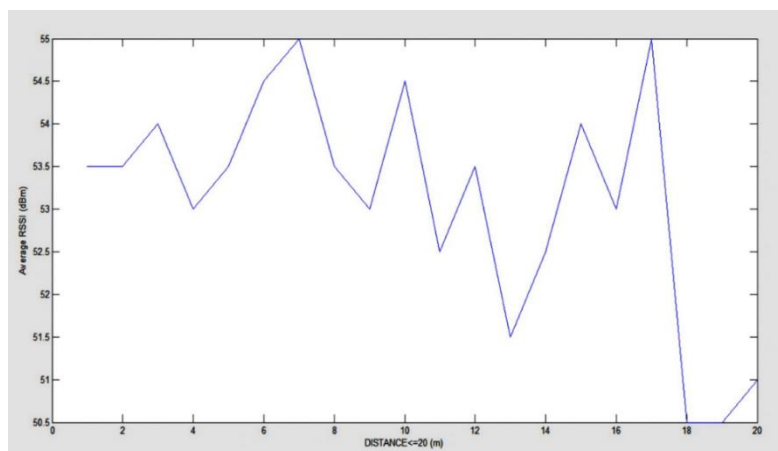

Figure 11 Graph of Average RSSI versus Average output power at distance ≤ 20 m

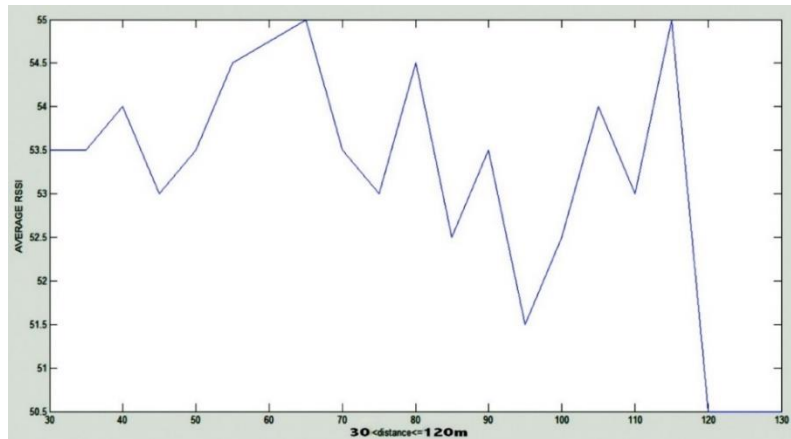

Figure 12 Graph of Average RSSI versus Average output power at 30 m <= distance <= 120 m

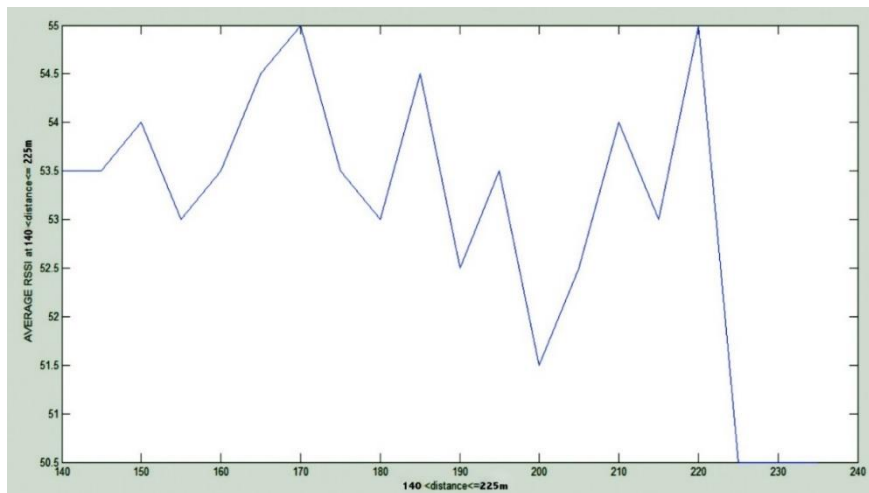

Figure 13 Graph of Average RSSI versus Average output power at 140 m <= distance <= 225 m

Conclusion

The Design and Implementation of Long Range WAN Monitoring System for Rural Farmers has been successfully developed and tested. The different hardware and software components and the methodologies have been properly described. The system developed offers a vast and efficient approach of monitoring the environmental conditions such as the temperature, pressure and humidity of any farm especially in the rural areas where network providers are not reliable. It does automatically and simultaneously transmit data from the sensor through the access point to different clients concurrently and wirelessly without any form of internet at the transmitter end. The systems low power consumption feature has been confirmed as the transmitter and receiver were successfully powered by just 9V 1A battery, which sets this technology (LoRa Tech) on a high demand even in the area of IoT.

The system also triggered DC sprinkler successfully when the set threshold values for pressure and temperature were met.

Acknowledgements

The authors are grateful to the Technical staff of the Department of Electrical and

Electronic Engineering, Federal University of Technology, Owerri for their support and guidance.

References

- [1] M. E. e. a. Ndubueze-Ogaraku, "Analysis of insecurity shocks and farmers' resilience in the Niger Delta," *Nigerian Agricultural Policy Research Journal*, vol. 2, no. 1, pp. 67-81, 2017.
- [2] The-Things-Network, "What are LoRa and LoRaWAN?," 6 May 2021. [Online]. Available: <https://www.thethingsnetwork.org/docs/lorawan/what-is-lorawan/>. [Accessed 6 May 2021].
- [3] Everything-RF, "What is LoRa?," 4 December 2018. [Online]. Available: [https://www.everythingrf.com/community/what-is-lora.](https://www.everythingrf.com/community/what-is-lora/) [Accessed 6 May 2021].
- [4] K. Mikhaylov, "Analysis of the Capacity and Scalability of the LoRa Wide Area Network Technology," in *ResearchGate*, Oulu, 2016.
- [5] Semtech, "What is LoRa?," 6 May 2021. [Online]. Available: [https://www.semtech.com/lora/what-is-lora.](https://www.semtech.com/lora/what-is-lora/) [Accessed 6 May 2021].
- [6] Semtech, "LoRa DNA of IoT," 6 May 2021. [Online]. Available: [https://www.semtech.com/lora.](https://www.semtech.com/lora/) [Accessed 6 May 2021].
- [7] P. Choudhari, "Smart Irrigation and Remote Farm Monitoring System," *International Journal of Computer Applications*, vol. 180, no. 38, pp. 24-26, May 2018.
- [8] S. Keller, "Moving to a wireless remote monitoring system," 31 July 2017. [Online]. Available: <https://www.controleng.com/articles/moving-to-a-wireless-remote-monitoring-system/>. [Accessed 6 May 2021].
- [9] C. Aravind, P. S. J. Suji and B. M. Ponni, "Remote Monitoring And Control Of Automation System With Internet Of Things," *International Journal of Scientific & Technology Research*, vol. 9, no. 1, pp. 945-949, January 2020.
- [10] S. Lin, Z. Ying and K. Zheng, "Design and Implementation of Location and Activity Monitoring System Based on LoRa," in *Key Lab of Universal Wireless Communications, Ministry of Education*, Beijing, 2021.
- [11] L. P. Fraile, S. Tsampas, G. Mylonas and D. Amaxilatis, "A Comparative Study of LoRa and IEEE 802.15.4-Based IoT Deployments Inside School Buildings," in *ICOMPUTER Technology Institute and Press-Diophantus*, Patras, 2020.
- [12] R. K. Kodali, S. Yerroju and S. Sahu, "Smart Farm Monitoring Using LoRa Enabled IoT," in *Second International Conference on Green Computing and Internet of Things (ICGCIoT)*, Telangana, 2018.